

Lined Plug Valves and Lined products

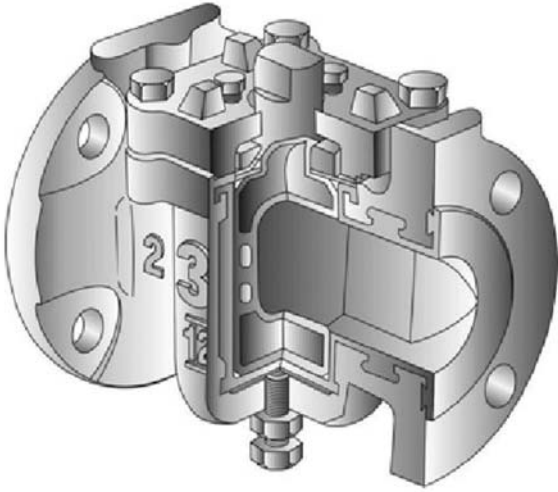

Fully-lined, quarter turn non-lubricated plug valve ideally suited for corrosive application. Locking of liner to body and molding technique permit use on many chemical services with higher pressures and vacuums without fear of liner collapse, shrinkage, stress cracking and blowout. Excellent sealing capability



3Z 2-way Lined Plug Valve
FIG 121, 321



3Z Bottomless Plug Valve
FIG 121, 321



3Z Lined Ball Check Valve
FIG 171, 371



3Z Lined Live Loaded Plug Valve
FIG 121LL, 331LL



3Z Lined Swing Check Valve
FIG 181, 381, 681



3Z Lined Strainer
FIG 190



3Z 3 way Lined Plug Valve
FIG 131, 331



3Z Lined Y-Type Strainer
FIG 191Y



3Z 5-way Lined Plug Valve
FIG 151, 351

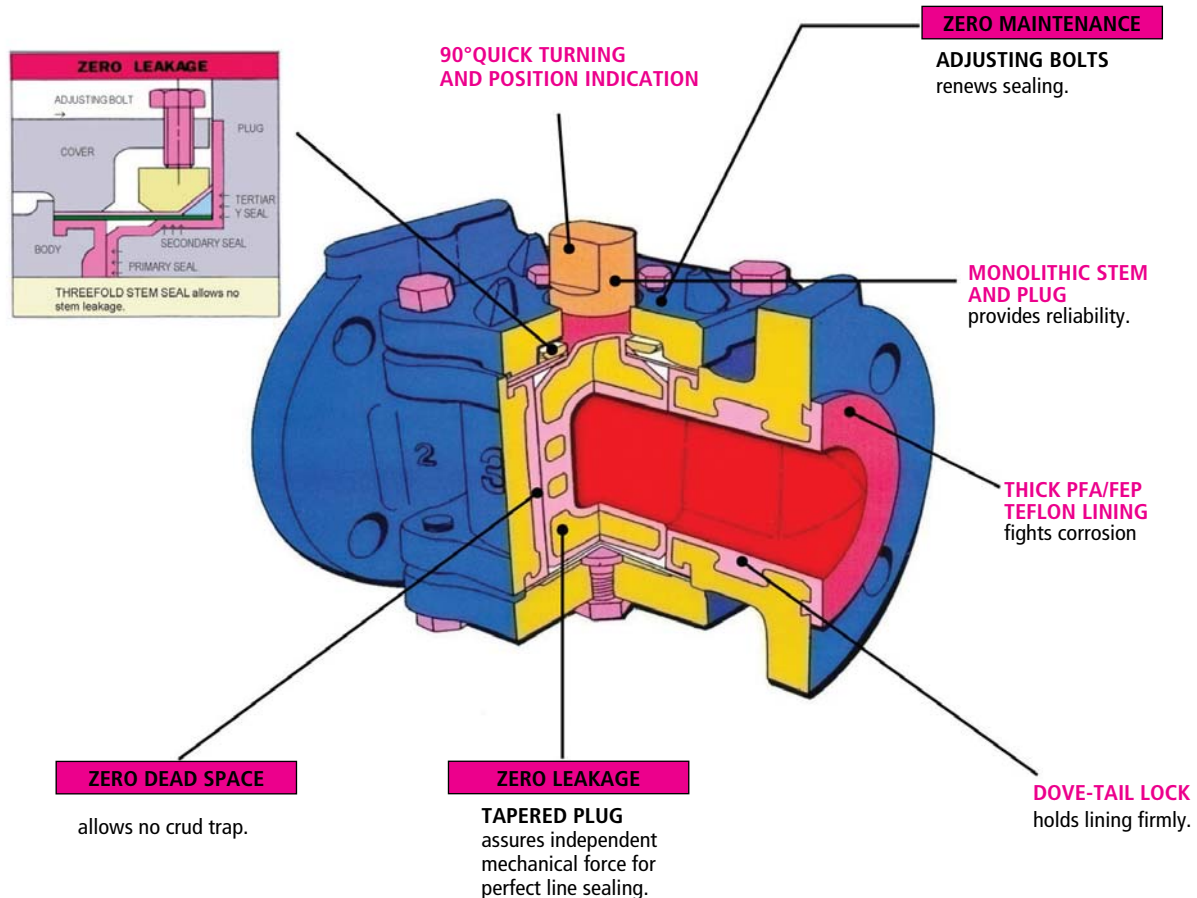

All sealing surfaces are machined to close tolerances, providing tight shutoff.

- (1) Independent wrench stops are cast in the cover.
- (2) Three stainless steel adjusting screws, silver-plated for added corrosion resistance, give parallelism to the plug through the thrust collar, assuring uniform position of the plug in the body.
- (3) The multiple top seal is designed to transmit sealing forces diagonally across the delta ring and vertically on the diaphragm to seal the plug shank, providing an added safeguard against hazardous fluids escaping to atmosphere
- (4) FEP and PFA are melt processible and offer maximum density and elimination of stress cracking at the corners, affording longer maintenance-free service for the liner and the valve.
- (5) The liner is locked to the casting by means of cast dovetail recesses and machined grooves, permitting the valve to be used on high vacuum and pressure applications without liner collapse, shrinkage or blowout.
- (6) The bottom seal adjustment provides a positive means of maintaining tight shutoff.
- (7) The body of the valve is coated with corrosion-resistant paint to retard external corrosion and rust.
- (8) Three-way valve has side entry design with choice of three port arrangements.

Construction & Materials

3Z Lined Plug Valve, 2-way Fig 121, 321

Fully-lined, quarter turn non-lubricated plug valve ideally suited for corrosive application. Locking of liner to body and molding technique permit use on many chemical services with higher pressures and vacuums without fear of liner collapse, shrinkage, stress cracking and blowout. Excellent sealing capability.

Linings : FEP, PFA
 Sizes : 1/2" - 18"
 Rating ANSI Class 150, 300

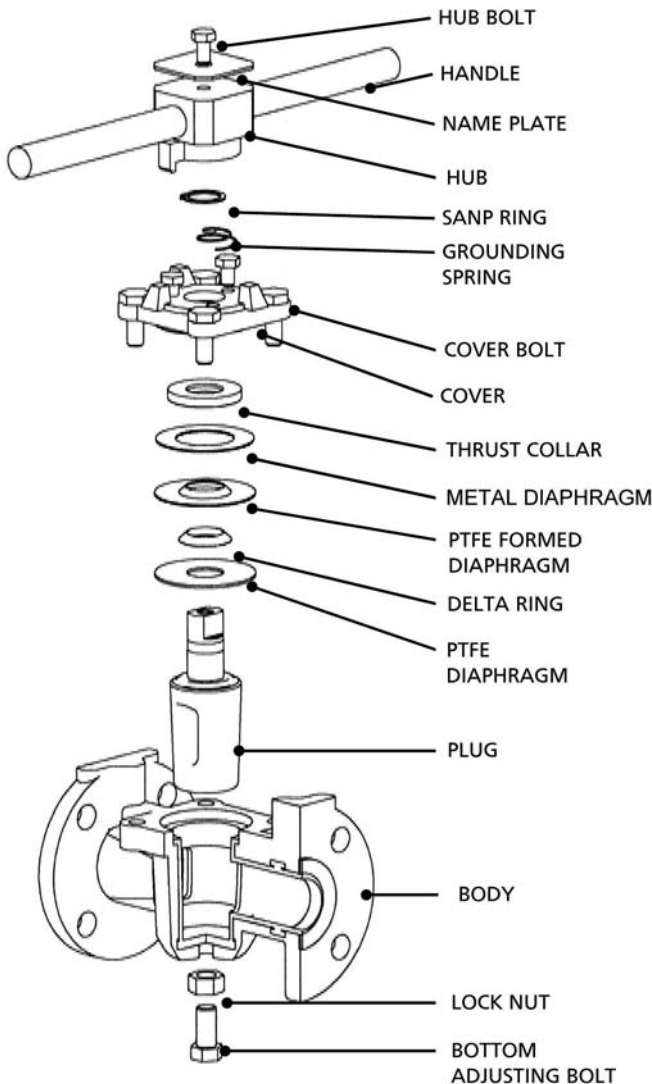

Materials of construction

Handle	Steel
Truarc ring	Steel, zinc plated
Static eliminator	Stainless steel
Cover nuts	Stainless steel
Adjusting screws	Stainless steel, silver plated
Top cover :	
121	Malleable iron
321	Carbon steel
130	Malleable iron
Thrust collar	Stainless steel
Formed diaphragm	PTFE
Delta ring	PTFE
Flat diaphragm	PTFE
Plug :	
121	FEP or PFA lined ductile iron
321	PFA lined ductile iron
130	FEP or PFA lined ductile iron

FIG 171

Size 1/2 through 6 inch, Class 150

Construction

The valve body is fully lined with either PFA or FEP teflon material. A RTFE ball is freely moving internally on spacer, but the movement is stopped by either flanged water way. Back pressure or backflow of the flow moves the ball upstream and the ball blocks the flow. Spacer at down stream has openings like a comb construction. Therefore, when there occurs a normal flow to downstream, the flow is free to flow.

Use & Function

- 1) Protection of pump motor from backflow damage.
- 2) Protection of pump impeller from backflow damage.
- 3) Certain degree of shut-off function when backhead is high.

Operation

- 1) 3Z FIG 171 can be mounted on "A" or "B".
- 2) When a pump stop signal is given during operation of the pump, the pump motor will be stopped but keeps running for a short period of time and gradually stops. At this time, if there is not 3Z FIG 171 installed, the backflow caused by back head will flow backward towards the pump.
- 3) On this occasion, motor and pump impeller can be damaged by the back flowing fluids because of the fighting direction of rotation.
- 4) But when a 3Z FIG 171 is mounted on the exit side of the pump, the backflow will push the ball inside 3Z FIG 171, seats the ball against the flanged water way bore instantly. Then, the back flow will seat the ball on the flange seat.
- 5) The higher the back pressure is, the greater the backflow forces. Therefore, the ball performs a shut-off function, but not tight shut-off. When a backhead is small, ball instantly

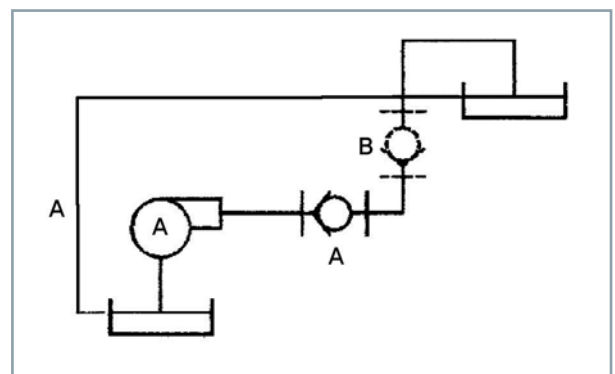

Fully Lined Ball Check Valves

prevents impact to the pump, but may move slightly from the shut off position. In this case, a partial backflow can occur to the pump, would not damage the pump impeller or motor because the backflow forces negligible.

6) 3Z FIG 171 can be mounted both horizontally and vertically. When mounted vertically, it operates with and aid of gravity.

7) When a tight shut-off is required for the back flow, and additional shut-off valve should be installed. Check valves are not designed for a shut-off function.

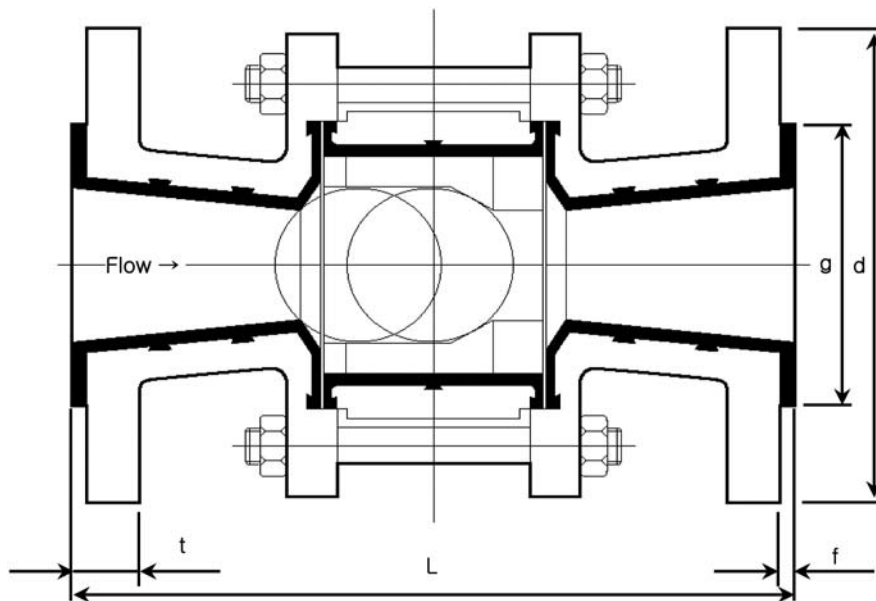

■ DIMENSIONS

SIZE		BOLT HOLE							
IN	MM	L	D	PCD	NO	DIA	g	t	f
1/2	15	152	89	60.5	4	16	35	15.5	3.2
3/4	20	152	98	70	4	16	43	15.9	3.2
1	25	152	108	79.5	4	16	51	17.3	3.8
1.1/2	40	178	127	98.5	4	16	73	18.1	3.8
2	50	203	152	120.5	4	19	92	20.3	4.4
2.1/2	65	242	178	139.5	4	19	105	24.1	5.0
3	80	242	190	152.5	4	19	121	24.1	5.0
4	100	292	229	190.5	8	19	147	29.2	5.3
6	150	394	279	241.5	8	22	206	31.2	5.8
8	200	482	343	298.5	8	22	264	35.1	6.5

FIG 181

3Z SWING CHECK VALVES ANSI Class 150 : 2"-12"

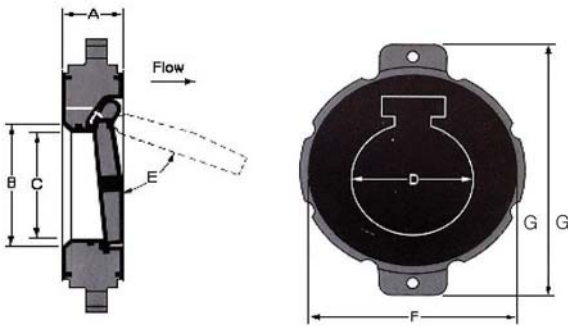

■ Features

- To be mounted horizontally and vertically in piping.
- To be used to replacing high alloy steel for corrosive process material
- No application of spring/pin causing corrosion or abrasion in Body.

■ Materials

- BODY WCB(316) / PFA (FEP)
- DISC FEP (PFA) : 4" and Under
WCB/PFA (FEP) : 6" and Over
Not less than 2.4_ of Lining thickness

■ Pressure Temperature Ratings

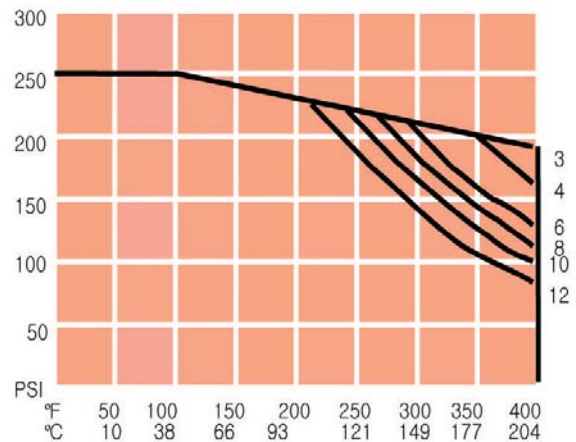

■ DIMENSIONS

SIZE	A	B	C	D	E	F	G	Wt(kg)	Cv	Max.matingl Flange I.D	
										Min	Max.
2	40	40	30	40.6	53°	89	172	1.9	45	43	49
3	46	55	45	56	55°	127	190	3.2	100	71	82
4	46	80	70	78	64°	157	266	5.9	234	92	100
6	57	125	111	124	65°	216	319	12.7	667	142	148
8	67	172	158	165	61°	298.5	373	22.7	1404	188	195
10	76	222	184	221	53°	324	394	28.6	1965	239	260
12	86	256	232	267	53°	381	510	42.2	3160	290	310

NO.	PART NAME	Q'TY	MATERIALS
1	BODY	1	CARBON STEEL
2	COVER	1	CARBON STEEL
3	PLUG	1	STAINLESS STEEL
4	COVER BOLT	1S	ALLOY STEEL
5	GROUNDING SPRING	1	CARBON STEEL
6	ADJUSTING BOLT(1)	3	STAINLESS STEEL
7	THRUST COLLAR	1	STAINLESS STEEL
8	METAL DIAPHR'M	1	STAINLESS STEEL
9	DELTA RING	1	RTFE
10	REVERS LIP	1	RTFE
11	LOCK NUT	1	STAINLESS STEEL
12	ADJUSTING BOLT(2)	3	STAINLESS STEEL
13	HUB	1	STAINLESS STEEL
14	HUB BOLT	1	STAINLESS STEEL
15	HANDLE	1	CARBON STEEL
16	NAME PLATE	1	STAINLESS STEEL
17	HANDLE NUT	1	STAINLESS STEEL

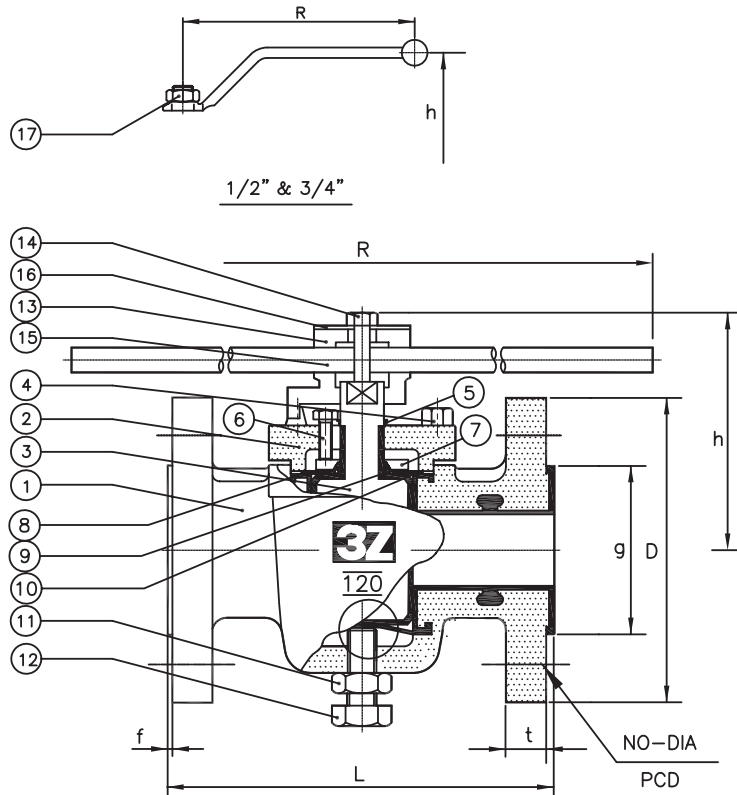

DIMENSIONS(mm)

NOMINAL SIZE		END FLANGES									
IN	MM	L	h	D	BOLT HOLE			g	t	f	R
					PCD	NO	DIA				
0.5	15	108	110	89	60.5	4	16	35	10	1.9	180
0.75	20	117	110	98	70	4	16	43	10.9	2.1	180
1	25	127	90.6	108	79.5	4	16	51	16.2	5	222
1.5	40	165	110.9	127	98.5	4	16	73	19.2	5	318
2	50	178	126	152	120.5	4	19	92	20.3	2.8	458
2.5	65	203	140.7	190	139.5	4	19	127	25.7	2.8	597
3	80	203	140.7	190	152.5	4	19	127	26.3	2.8	597
4	100	229	174.4	229	190.5	8	19	157	29.7	5.8	746

END CONNECTION : RF	
TEST	ANSI B 16.34
FACE TO FACE or END TO END	ANSI B 16.10 CLASS 150
DIMENSIONS OF FLANGE	ANSI B 16.5 CLASS 150
WALL THICKNESS	ANSI B 16.34 CLASS 150
	LINED PLUG VALVES
	PRODUCTION NO. 121.1-W.P

NO.	PART NAME	Q'TY	MATERIALS
1	BODY	1	CARBON STEEL
2	COVER	1	CARBON STEEL
3	PLUG	1	STAINLESS STEEL
4	COVER BOLT	1S	ALLOY STEEL
5	ADJUSTING BOLT(1)	3	STAINLESS STEEL
6	THRUST COLLAR	1	STAINLESS STEEL
7	METAL DIAPHR'M	1	STAINLESS STEEL
8	DELTA RING	1	RTFE
9	REVERS LIP	1	RTFE
10	LOCK NUT	1	STAINLESS STEEL
11	ADJUSTING BOLT(2)	3	STAINLESS STEEL
12	GEAR OPERATOR	1	STEEL
13	TORQUE BAR	1	CARBON STEEL
14	COMPENSATOR	1	CARBON STEEL
15	BRACKET	1	CARBON STEEL
16	BRACKET BOLT	1	STAINLESS STEEL
17	NAME PLATE	1	STAINLESS STEEL

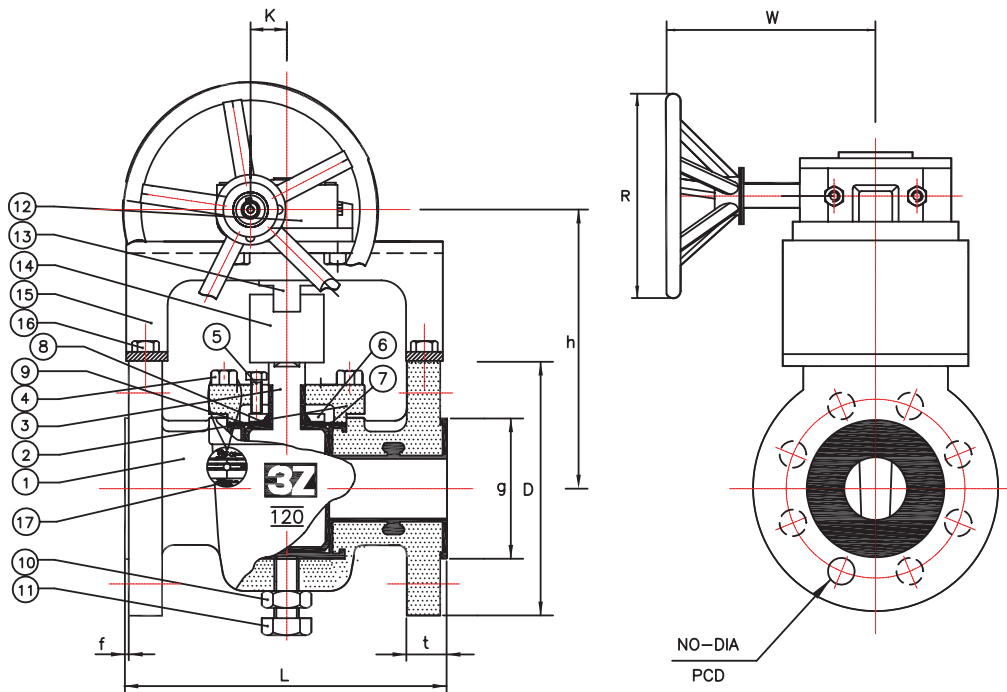

NOMINAL SIZE		DIMENSIONS(mm)												
IN	MM	L	h	D	END FLANGES			g	t	f	R	K	W	
					PCD	NO	DIA							
6	150	267	282	279	241.5	8	22	211	33	3.5	200	75	235	
*	8	200	292	334.5	343	298.5	8	22	267	32.9	5.9	255	92	288
**	10	250	330	366	406	362	12	25	319	35.4	6.8	255	92	288

NOTE.		END CONNECTION : RF	
D S	1. * 2 TOP, 2 BOTTOM HOLES IN FLANGES ARE TAPPING FOR 3/4-10UNC	TEST	ANSI B 16.34
	2. ** 2 TOP, 2 BOTTOM HOLES IN FLANGES ARE TAPPING FOR 7/8-9UNC	FACE TO FACE or END TO END	ANSI B 16.10 CLASS 150
		DIMENSIONS OF FLANGE	ANSI B 16.5 CLASS 150
		WALL THICKNESS	ANSI B 16.34 CLASS 150
LINED PLUG VALVES		PRODUCTION NO.	
		121.2-W.P	

NO.	PART NAME	Q'TY	MATERIALS
1	BODY	1	CARBON STEEL
2	COVER	1	CARBON STEEL
3	PLUG	1	STAINLESS STEEL
4	COVER BOLT	1S	ALLOY STEEL
5	GROUNDING SPRING	1	CARBON STEEL
6	ADJUSTING BOLT(1)	3	STAINLESS STEEL
7	THRUST COLLAR	1	STAINLESS STEEL
8	METAL DIAPHR'M	1	STAINLESS STEEL
9	DELTA RING	1	RTFE
10	REVERS LIP	1	RTFE
11	LOCK NUT	1	STAINLESS STEEL
12	ADJUSTING BOLT(2)	3	STAINLESS STEEL
13	HUB	1	STAINLESS STEEL
14	HUB BOLT	1	STAINLESS STEEL
15	HANDLE	1	CARBON STEEL
16	NAME PLATE	1	STAINLESS STEEL
17	HANDLE NUT	1	STAINLESS STEEL

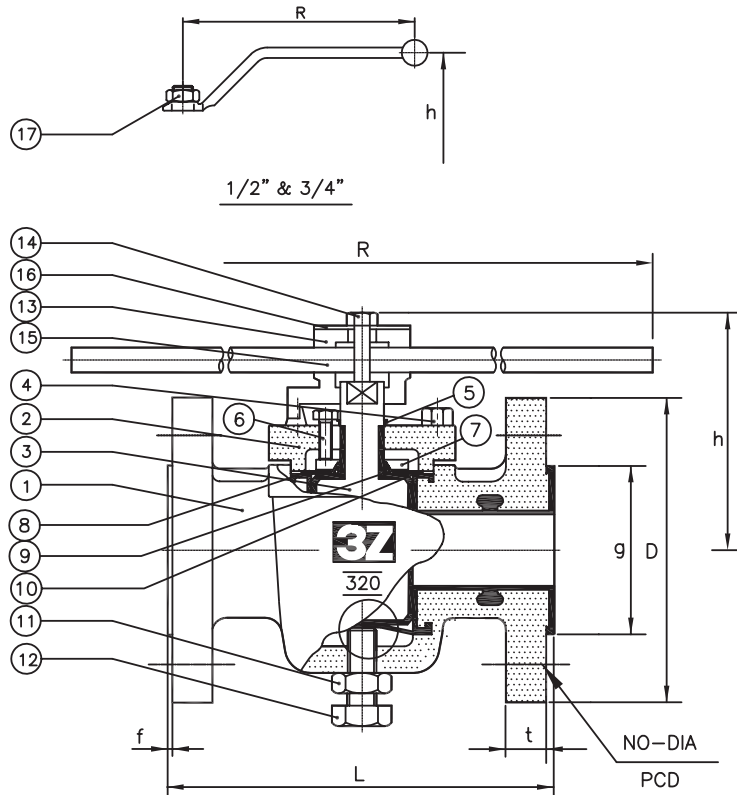

DIMENSIONS(mm)

NOMINAL SIZE		END FLANGES									
IN	MM	L	h	D	BOLT HOLE			g	t	f	R
					PCD	NO	DIA				
0.5	15	140	110	95	66.5	4	16	35	14.2	1.5	180
0.75	20	152	110	117	82.5	4	19	43	16	2.1	180
1	25	165	90.6	124	89	4	19	51	22.6	2.4	222
1.5	40	190	110.9	156	114.5	4	22	73	25.7	2.4	318
2	50	216	126	165	127	8	19	92	27.8	2.8	458
3	80	283	140.7	210	168	8	22	127	33.5	2.8	597
4	100	305	174.4	254	200	8	22	157	37.6	5.8	746

END CONNECTION : RF	
TEST	ANSI B 16.34
FACE TO FACE or END TO END	ANSI B 16.10 CLASS 300
DIMENSIONS OF FLANGE	ANSI B 16.5 CLASS 300
WALL THICKNESS	ANSI B 16.34 CLASS 300
	LINED PLUG VALVES
	PRODUCTION NO. 321.1-W.P

NO.	PART NAME	Q'TY	MATERIALS
1	BODY	1	CARBON STEEL
2	COVER	1	CARBON STEEL
3	PLUG	1	STAINLESS STEEL
4	COVER BOLT	1S	ALLOY STEEL
5	ADJUSTING BOLT(1)	3	STAINLESS STEEL
6	THRUST COLLAR	1	STAINLESS STEEL
7	METAL DIAPHR'M	1	STAINLESS STEEL
8	DELTA RING	1	RTFE
9	REVERS LIP	1	RTFE
10	LOCK NUT	1	STAINLESS STEEL
11	ADJUSTING BOLT(2)	3	STAINLESS STEEL
12	GEAR OPERATOR	1	STEEL
13	TORQUE BAR	1	CARBON STEEL
14	COMPENSATOR	1	CARBON STEEL
15	BRACKET	1	CARBON STEEL
16	BRACKET BOLT	1	STAINLESS STEEL
17	NAME PLATE	1	STAINLESS STEEL

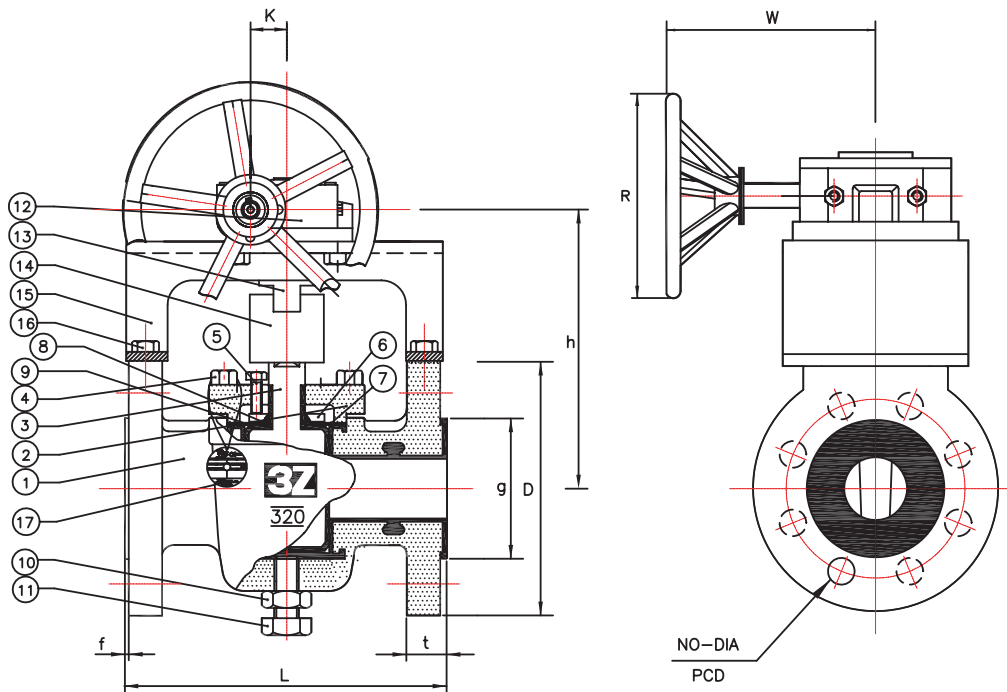

NOMINAL SIZE		END FLANGES											DIMENSIONS(mm)		
IN	MM	L	h	D	BOLT HOLE			g	t	f	R	K	W		
					PCD	NO	DIA								
6	150	403	282	318	270	12	22	229	39.8	3.3	200	75	235		

END CONNECTION : RF	
TEST	ANSI B 16.34
FACE TO FACE or END TO END	ANSI B 16.10 CLASS 300
DIMENSIONS OF FLANGE	ANSI B 16.5 CLASS 300
WALL THICKNESS	ANSI B 16.34 CLASS 300
3Z	LINED PLUG VALVES
	PRODUCTION NO. 321.2-W.P